



**ASSISTMACH**

**ULTRA | MAXIMA | S-CUT | V-CUT | M-CUT**  
BENDING AND CUTTING TECHNOLOGIES



[www.assistmach.com](http://www.assistmach.com)





ASSISTMACH





We don't offer only standard machines,  
we offer solutions for the best production types.

## 2 production platforms press brakes and hydraulic shears

Press Brakes,

- Ultra Series
- Maxima Series

Hydraulic Shears

- S-Cut Swing Beam Shears
- V-Cut CNC Variable Rake Shears
- M-Cut Mechanical Shears

For more than 15 years of experience on sales and direct production field experience gives confidence on performance, quality and service for all our operators.



ASSISTMACH



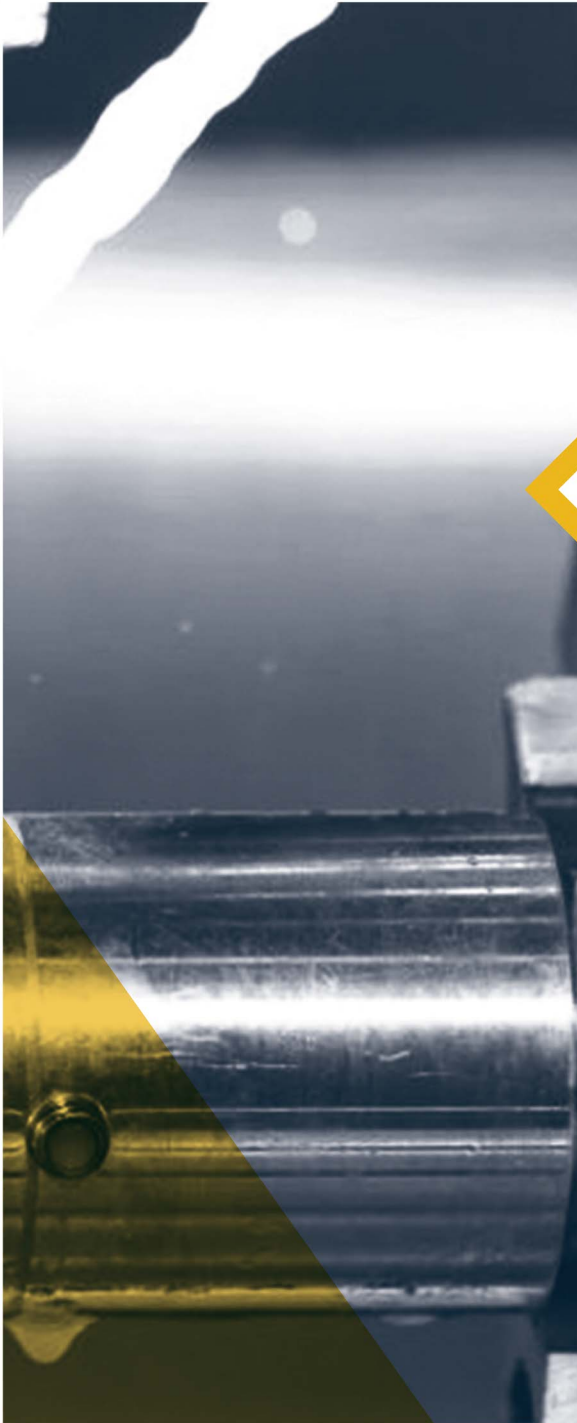

## VISION AND MISSION

We point at making bending and cutting sheet metal an easy, precise and reliable process. We aim to make our clients more productive and quality job.

Our point is to become a constant point of reference in the theory and practice of our machines.

# ULTRA SERIES

## 4 AXIS CNC HYDRAULIC PRESS BRAKES

### GENERAL SPECIFICATIONS

Hydraulic operation with two cylinders - Assistmach  
High performance hydraulic gear pump - Rexroth  
High pressure filter (with clogging detector and bypass) placed before all components  
Air removal filter in the reservoir  
Fast descent by gravity, bending phase and return of the ram are controlled electronically via a proportional flow valves - Rexroth  
Bending force controlled by proportional pressure valves - Rexroth  
Quality oil with high viscosity index  
Frame is designed and sized using Analyze program  
Hydraulic components from leading companies worldwide (Rexroth )  
Connectors and system tube sizing according to din regulations  
Flanged connectors and hoses according to sae regulations  
Construction of cylinders with high quality materials, hardening and very accurate finishing for the sliding surfaces  
Choice of seals and sizing of the housings is a result of many years of experience  
Preventive system flushing and thorough testing  
We only use welded steel with high tensile strength and stiffness

CE



High  
Capacity

Strong  
and  
Rigid Body

Low  
Service  
Cost

Fast and  
Precise  
Bending

Reliability





## FEATURES OF ULTRA SERIES

8



- Standard 2 axis backgauge
- Fast and high accuracy servo motors
- Resistance to crash
- Maintenance free



Precise and Robust Back Gauge system





Quick release clamping



Mitsubishi Servo Motors



Front support arms with brushes are mounted on a linear guide rail system



Linear encoder - Opkon/GIVI

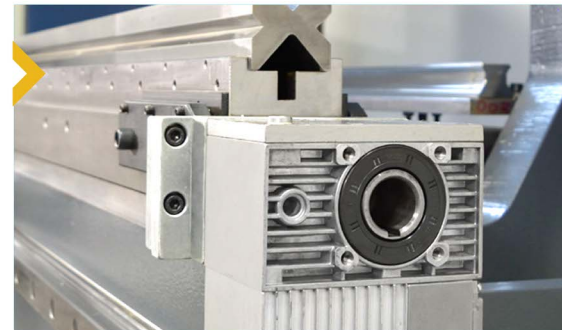

CNC controlled motorized crowning system - Option



CE Safety system

Our machines are designed in accordance with Ce-Norms to ensure your safety with hydraulic, electric, appropriate height covers and laser light curtains. CE safety in tandem machines are also provided with light barriers

# ULTRA SERIES CONTROL UNITS

## Cybelec CybTouch 15 (Standard)



10

### CUSTOMER BENEFITS

Y1, Y2, X and R axes, the optional Z1 and Z2 axes, and motorized crowning are supported

15" capacitive touchscreen with glass surface

Collision detection

Bending sequence computation

## Cybelec Modeva 19T



### CUSTOMER BENEFITS

Large touchscreen with a customizable area

Comfort and power with a flat and modern design

Direct import from most CAD/CAM systems

## Delem 66 T

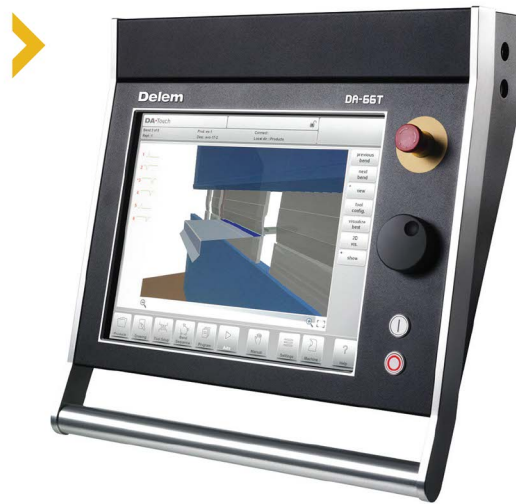

### CUSTOMER BENEFITS

2D graphical touch screen programming mode

17" high resolution colour TFT

Sensor bending & correction interface

## Delem 69 T



### CUSTOMER BENEFITS

3D and 2D graphical touch screen programming mode

3D visualisation in simulation and production

Profile-T3D offline software



## Standard Equipments

Y1, Y2, X, R - 4- axis  
 Control Unit - Cybelec CybTouch 15 or Delem 58T  
 Non CE with manual F.AKAS FPBS (for top beam)  
 Mitsubishi servo motor back gauge & ball screw system (X-R)  
 CNC controlled motorized crowing system  
 60mm. die holder  
 Quick Release European top clamping system  
 Sliding front arms with brushes  
 Special cover design  
 Rexroth hydraulic block and valves  
 World standard electric equipments  
 LED lights on front cover

## Optional Equipments

Control unit - ModEva 19 T or Delem 66T  
 CE Manual Fiessler-FMSC-A-M and Akas LC-II-M (safeyt PLC)  
 DSP safety system + MCS (safety PLC)  
 Z1, Z2 axis  
 X1, X2 axis  
 R1, R2 axis  
 Delta X axis,  
 X axis = 1000 mm - light barrier back protection  
 Wila PRO and PREMIUM Top and Bottom clamping systems  
 AP3-AP4 sheet followers  
 Parking area  
 Central lubrication system  
 Oil cooler  
 Additional back gauge finger and sliding front support arms  
 Special packing for overseas shipments

12

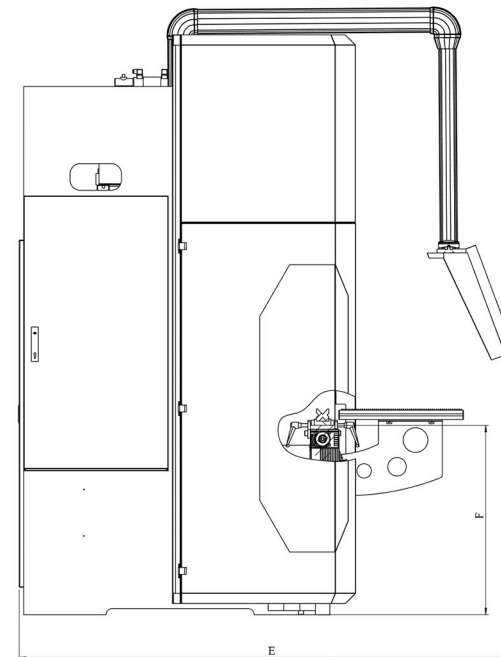
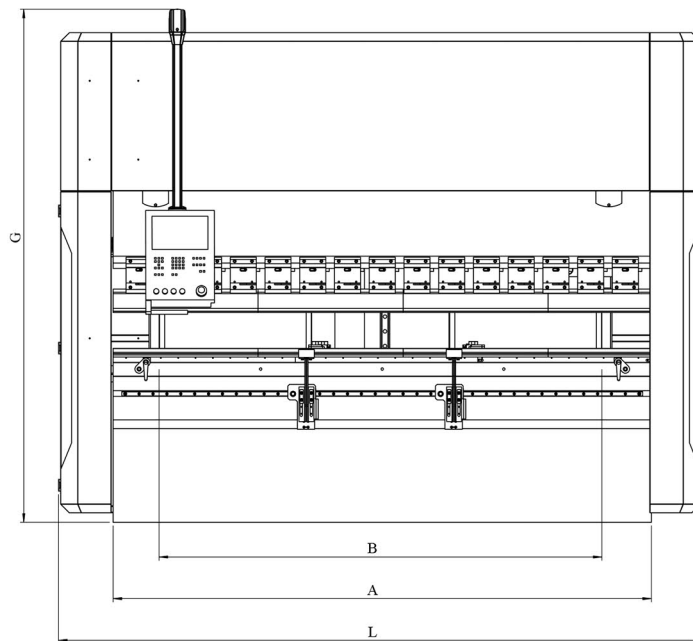

ULTRA SERIES CNC HYDRAULIC PRESS BRAKES

TYPE	Bending Length	Bending Force	Stroke	Between Columns	Y Axis Down Speed	Y Axis Bending Speed	Y Axis Return Speed	X Axis Distance	R Axis Distance	X Axis Speed	Length	Width	Height	Width	Throat Depth	Table Height	Daylight	Bottom Table Dimension	Motor	Oil Tank	Weight
	A	I	B	mm/sec	mm/sec	mm/sec	mm	mm	mm/sec												
	mm	Ton	mm	mm	mm/sec	mm/sec	mm/sec	mm	mm	mm/sec											
Machine Transport Dimension											L	D	G	E	H	F	J	K	kW	lt	kg
ULTRA-1260	1300	60	180	1000	180	10	140	650	250	350	2130	1990	2375	2400	400	850	400	120	7,5	100	3250
ULTRA-2060	2100	60	270	1650	180	10	140	650	250	350	2830	1990	2375	2400	450	850	550	120	7,5	100	3750
ULTRA-25100	2600	100	270	2100	180	10	140	650	250	350	3300	1700	2760	2150	450	850	550	120	11	200	6500
ULTRA-31100	3100	100	270	2550	180	10	140	650	250	350	3760	1700	2760	2150	450	850	550	120	11	200	7800
ULTRA-31135	3100	135	270	2550	160	10	120	650	250	350	3760	1700	2760	2150	450	850	550	120	15	200	8900
ULTRA-31175	3100	175	270	2550	160	10	120	650	250	350	3775	1825	2920	2250	450	920	550	120	18,5	200	9800
ULTRA-31220	3100	220	270	2550	140	10	120	650	250	350	3775	1830	2960	2270	450	920	550	120	22	200	11500
ULTRA-31300	3100	300	370	2550	140	10	100	650	250	350	3810	2050	3100	2550	450	920	650	150	37	300	14500
ULTRA-31400	3100	400	370	2550	100	10	100	650	250	350	3990	2250	3280	2700	550	1030	650	150	37	400	20500
ULTRA-37175	3700	175	270	3100	140	10	120	650	250	350	4325	1825	2920	2250	450	920	550	120	17,5	200	12000
ULTRA-37220	3700	220	270	3100	140	10	120	650	250	350	4325	1830	2960	2270	450	920	550	120	22	200	13500
ULTRA-37300	3700	300	370	3100	140	10	100	650	250	350	4360	2110	3150	2690	450	920	650	150	37	300	15500
ULTRA-41175	4100	175	270	3550	140	10	120	650	250	350	4675	1825	2920	2250	450	920	550	120	18,5	200	13000
ULTRA-41220	4100	220	270	3550	140	10	100	650	250	350	4675	1830	2960	2270	450	920	550	120	22	200	14500
ULTRA-41300	4100	300	370	3550	120	10	100	650	250	350	4710	2050	3100	2550	450	920	650	150	37	300	18000
ULTRA-41400	4100	400	370	3550	100	10	80	650	250	350	4990	2250	3280	2700	550	1030	650	150	37	400	23000
ULTRA-61220	6100	200	270	5100	120	10	100	650	250	350	6675	1850	2960	2250	450	1050	550	120	22	200	21000
ULTRA-61300	6100	300	370	5100	100	10	100	650	250	350	6675	2050	3100	2550	450	920	650	150	37	300	25500
ULTRA-61400	6100	400	370	5100	100	10	80	650	250	350	6660	2250	3280	2700	550	1030	650	150	37	400	31000
ULTRA-61500	6100	500	370	5100	100	10	80	650	250	350	6680	2300	3350	2850	550	1070	650	150	37	400	34000
ULTRA-61600	6100	600	370	5100	80	10	80	650	250	350	6720	2650	5100	3780	550	2230	650	150	45	500	53000

# MAXIMA SERIES

## 3 AXIS CNC HYDRAULIC PRESS BRAKES

### GENERAL SPECIFICATIONS

Hydraulic operation with two cylinders - Assistmach  
High performance hydraulic gear pump - Rexroth  
High pressure filter (with clogging detector and bypass) placed before all components  
Air removal filter in the reservoir  
Fast descent by gravity, bending phase and return of the ram are controlled electronically via a proportional flow valves - Rexroth  
Bending force controlled by proportional pressure valves - Rexroth  
Quality oil with high viscosity index  
Frame is designed and sized using Analyze program  
Hydraulic components from leading companies worldwide - Rexroth  
Connectors and system tube sizing according to din regulations  
Flanged connectors and hoses according to sae regulations  
Construction of cylinders with high quality materials, hardening and very accurate finishing for the sliding surfaces  
Choice of seals and sizing of the housings is a result of many years of experience  
Preventive system flushing and thorough testing  
We only use welded steel with high tensile strength and stiffness



Easy  
to  
Use

Ergonomic

Budget  
Friendly

Fast  
&  
Productive

Minimum  
Setting  
Time





## FEATURES OF MAXIMA SERIES

16



Standard manual height adjustable fingers



Precise and Robust Back Gauge system





Top and Bottom Clamping system  
Quick release clamping



European Type Bottom Tool (4V Die)



Front support arms with brushes are mounted on a linear guide rail system

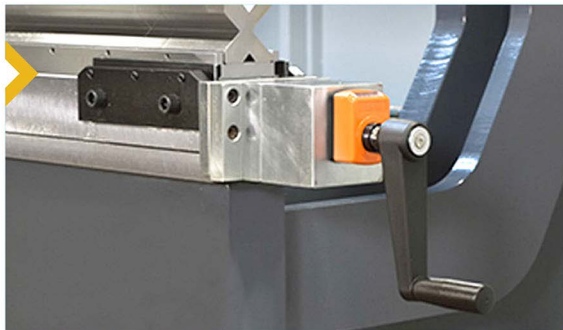

Manual Crowning system - Standard

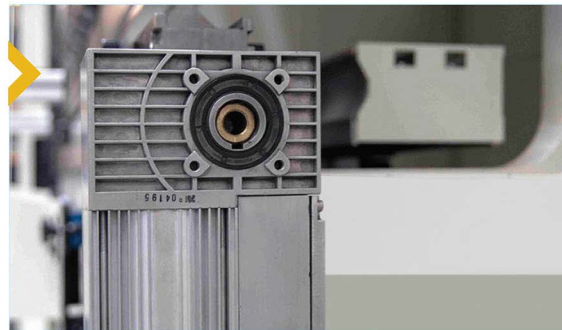

CNC controlled motorized crowning system - Option



CE Safety system

Our machines are designed in accordance with Ce-Norms to ensure your safety with hydraulic, electric, appropriate height covers and laser light curtains. CE safety in tandem machines are also provided with light barriers



# MAXIMA SERIES CONTROL UNITS

## Cybelec CybTouch 12 (Standard)



18

### CUSTOMER BENEFITS

Open to any operator thanks to the simple and intuitive full touch screen programming

Modern and efficient hand drawing part profile programming

Very fast solution provided by 2D graphic display and automatic bending sequence

## Cybelec CybTouch 15



### CUSTOMER BENEFITS

Y1, Y2, X and R axes, the optional Z1 and Z2 axes, and motorized crowning are supported

15" capacitive touchscreen with glass surface

Collision detection

Bending sequence computation

## DELEM 58 T



The DA-58T is a state of the art complete 2D graphical control solution for synchronized press brakes. Offering easiest CNC programming based on the Delem graphical touch screen user interface including automatic bend sequence calculation and collision detection.

Its 15" high resolution colour TFT, with industrial grade multi touch screen technology, gives access to the proven Delem user-interface. It enables direct navigation between product programming and actual production. Functions are directly located where needed, offering optimised ergonomics throughout the entire application.

- 2D graphical touch screen programming
- 15" high resolution colour TFT
- Bend sequence calculation
- Crowning control
- Servo and frequency inverter control
- Advanced Y-axis control algorithms for closed-loop as well as open-loop valves.
- USB, peripheral interfacing
- Profile-T offline software





### Standard Equipments

- (Y1, Y2, X) 3 axis Synchro Press Brake
- Manual Crowning
- Control Unit - CNC Cybelec Cytbtouch 12 Graphic Control
- Non CE with Manual F.AKAS FPBS (for Top Beam )
- European Quick Release Clamping system
- 60mm Die Holder
- Back gauge : Motorised & Ballscrew system
- Back gauge fingers – manual height adjustable
- Back gauge motors: AC motors
- Sliding Front Arms with full length linear guide and brushes
- Safety covers

20

### Optional Equipments

- Cybelec CybTouch 15
- Delem 58T Control Unit
- Delem 66T control Unit
- CE Norm with DSP Top beam safety with PLC included
- Manual FIESSLER AKAS + FPSC (safety PLC)
- R axis
- CNC Controlled motorized crowning system
- Oil coolant
- Oil Heater
- Additional Front arms
- Additional back gauge fingers
- Control Panel on opposite side

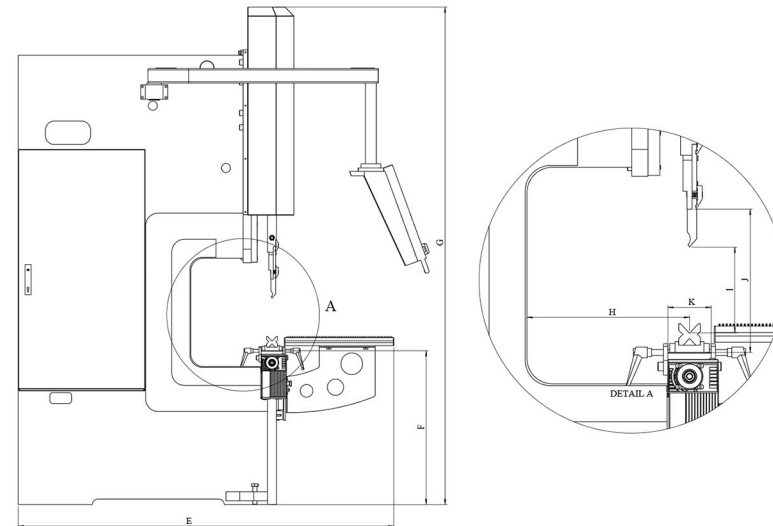
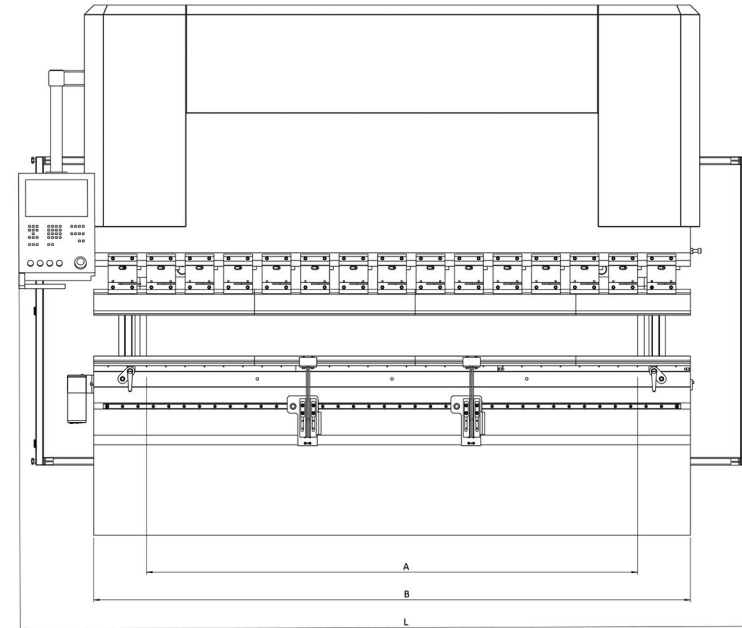

MAXIMA SERIES 3 AXIS HYDRAULIC PRESS BRAKES

TYPE	Bending Length	Bending Force	Stroke	Between Columns	Y Axis Down Speed	Y Axis Bending Speed	Y Axis Return Speed	X Axis Distance	X Axis Speed	Length	Width	Height	Width	Throat Depth	Table Height	Daylight	Bottom Table Dimension	Motor	Oil Tank	Weight
	B	I	A	mm/sec	mm/sec	mm/sec	mm	mm/sec	L											
										Machine Transport Dimension										
MAXIMA-1240	1300	40	180	1000	160	10	140	650	350	2125	1950	2150	2100	300	770	345	100	5.5	100	2500
MAXIMA-1260	1300	60	180	1000	160	10	140	650	350	2130	1990	2375	2400	400	850	400	100	5.5	100	3100
MAXIMA-2060	2100	60	270	1650	160	10	140	650	350	2830	1990	2375	2400	450	850	550	100	5.5	100	3500
MAXIMA-25100	2600	100	270	2100	160	10	120	650	350	3300	1700	2760	2150	450	850	550	100	7.5	200	6500
MAXIMA-31100	3100	100	270	2550	160	10	120	650	350	3760	1700	2760	2150	450	850	550	100	7.5	200	7500
MAXIMA-31135	3100	135	270	2550	160	10	120	650	350	3760	1700	2760	2150	450	850	550	120	11	200	8500
MAXIMA-31175	3100	175	270	2550	160	10	120	650	350	3775	1825	2920	2250	450	920	550	120	15	200	9600
MAXIMA-31220	3100	220	270	2550	140	10	120	650	350	3775	1830	2960	2270	450	920	550	120	18.5	200	11000
MAXIMA-31300	3100	300	370	2550	140	10	100	650	350	3810	2050	3100	2550	450	920	650	150	30	300	13800
MAXIMA-31400	3100	400	370	2550	100	10	100	650	350	3990	2250	3280	2700	550	1030	650	150	37	400	19500
MAXIMA-37175	3700	175	270	3100	140	10	120	650	350	4325	1825	2920	2250	450	920	550	120	15	200	11200
MAXIMA-37220	3700	220	270	3100	140	10	120	650	350	4325	1830	2960	2270	450	920	550	120	18.5	200	12300
MAXIMA-37300	3700	300	370	3100	140	10	100	650	350	4360	2110	3150	2690	450	920	650	150	30	300	14800
MAXIMA-41175	4100	175	270	3550	140	10	120	650	350	4675	1825	2920	2250	450	920	550	120	15	200	11600
MAXIMA-41220	4100	220	270	3550	140	10	100	650	350	4675	1830	2960	2270	450	920	550	120	18.5	200	13200
MAXIMA-41300	4100	300	370	3550	120	10	100	650	350	4710	2050	3100	2550	450	920	650	150	30	300	17000
MAXIMA-41400	4100	400	370	3550	100	10	80	650	350	4990	2250	3280	2700	550	1030	650	150	37	400	22000
MAXIMA-61220	6100	200	270	5100	120	10	100	650	350	6675	1850	2960	2250	450	1050	550	120	18.5	200	19800
MAXIMA-61300	6100	300	370	5100	100	10	100	650	350	6675	2050	3100	2550	450	920	650	150	30	300	23550
MAXIMA-61400	6100	400	370	5100	100	10	80	650	350	6660	2250	3280	2700	550	1030	650	150	37	400	30000
MAXIMA-61500	6100	500	370	5100	100	10	80	650	350	6680	2300	3350	2850	550	1070	650	150	37	400	31500
MAXIMA-61600	6100	600	370	5100	80	10	80	650	350	6720	2650	5100	3780	550	2230	650	150	45	500	51400

# S-CUT SERIES

## HYDRAULIC SWING BEAM GUILLOTINE SHEARS

High Performance, durable cutting and rigid body allows you perfect cutting quality

### GENERAL SPECIFICATIONS

- Strong body for perfect cutting
- Hardened and ground blades for long life
- Proved and rigid design with swing beam top table
- CNC controlled motorized blade gap adjustment
- CE standards and security
- The combination of economic and perfect cutting performance
- User friendly CNC touch screen control unit by CybeleC
- Automatic swing up back gauge
- Sheet support arms
- Iron ball transfer tables and front support arms
- Illumination and shadow line



User  
Friendly

Economic

Heavy Duty

Perfect  
Cutting

Robust Body





## FEATURES OF S-CUT SERIES

24



Strong and precise back gauge  
Motorized blade gap adjustment by control unit  
Back covers with light barriers  
Sheet slider at the back

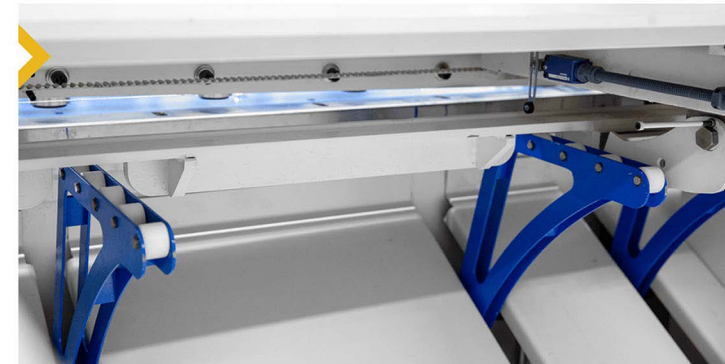

Option: Pneumatic thin sheet support



## Cybelec CybTouch 8



### CUSTOMER BENEFITS

Very simple to use with intuitive touch screen programming

Higher quality and productivity increase

Powerful features for maximum output

### Easy Operating

- High-contrast touchscreen, with vivid colors
- Simple pages, large keys, clear display with all the information the operator needs
- Intuitive and user-friendly interface
- Complete programming of parts in seconds
- Quick set up of the machine with the EasyCut page.
- Contextual help and warning pop-up

### Better Cutting

- Automatic calculations of the shear functions upon material specifications
- Automatic blade gap
- Automatic cutting angle
- Automatic cutting length
- Automatic back gauge correction
- Automatic back gauge foldaway
- Anti-twist management
- 2/3- position sheet support
- Return to sender function (RTS)
- Front or back gauge management
- Parking position (foldaway function)
- Hold-downs pressure management
- System pressure management
- Sheet position offset, allowing to cut in the middle

### Powerful

- Large cutting sequences and programs can be memorized
- Easy communication via wireless connection to a laptop computer
- Over 10 languages available



## Standard Equipments

CybTouch 8 Control Unit-Touch screen  
 CE-Norm  
 Sheet Slider at rear  
 Motorized Blade gap adjustment  
 Ball screw back gauge 1000 mm  
 1 mt. Flip up finger guards with flexi glass  
 1 Squaring arm L= 1500 mm, with scale & T-Slot  
 2 Support arms L=1000 mm, with T-Slot  
 Ball Transfer Tables  
 Stroke Counter from control unit  
 Rubber pads for holddowns  
 Illumination & Shadow wire  
 Top 2 side & Bottom blades with 4 side

## Optional Equipments

Light Curtains for Finger Protection  
 Pneumatic thin sheet support device  
 add. Support Arms L= 2 m with vertical support for each  
 add. Support Arms L= 3 m (1 pc.) with vertical support  
 Extension Support Arms L= 2 m (1 pc.) with vertical support  
 Extension Support Arms L= 3 m (1 pc.) with vertical support  
 Extension Squaring Arm L= 2 m (1 pc.) with vertical support  
 Extension Squaring Arm L= 3 m (1 pc.) with vertical support  
 Ball integrated squaring arms or support arms  
 Adjustable Angle stop 0-180°  
 Laser Cutting Line  
 Spare-Blades: Standard Top and Bottom Blade (1 set)  
 Oil Coolant  
 Special Colour  
 Oil heater

26

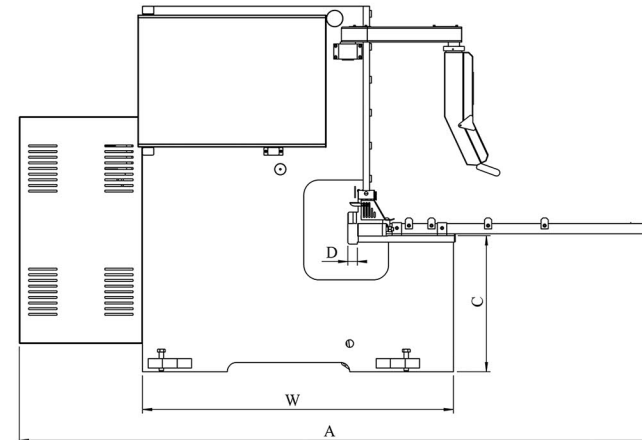
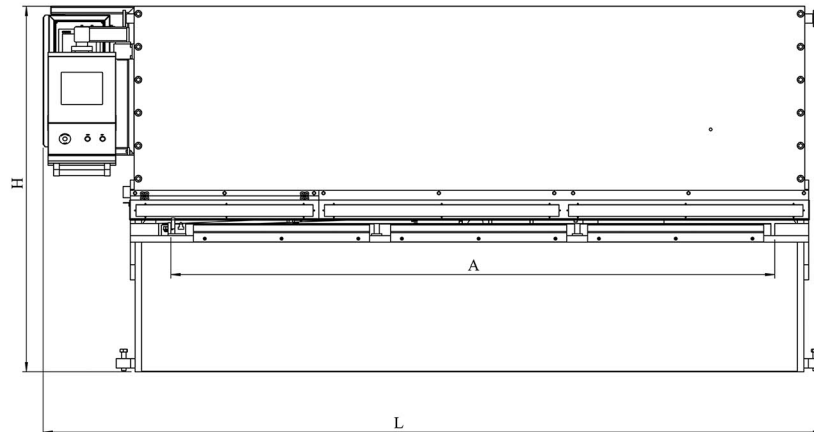

## S-CUT SERIES HYDRAULIC SWING BEAM SHEARS

TYPE	Cutting Angle	Cutting Length	Capacity	Length	Width	Height	Width	Throat Depth	Table Height	Hold Down Pistons	Motor	Back Gauge Motor	Back Gauge Range	Back Gauge Speed	Cutting Stroke	Oil Tank	Weight	
	(°)	A mm	St 42 mm	L mm	W1 mm	H mm	W mm	D mm	C mm	pcs	kW	kW	mm	mm/sec	1/min	lt	kg	
				Machine Transport Dimension														
SCUT 2106	1.5°	2100	6	3100	1800	1650	3430	50	760	10	11	0.75	1000	200	16	200	4800	
SCUT 2506	1.5°	2600	6	3600	1850	1800	3430	50	760	13	11	0.75	1000	200	16	200	5700	
SCUT 3106	1.5°	3100	6	4110	2195	1770	2665	250	790	15	15	0.75	1000	200	16	300	7000	
SCUT 3110	1.8°	3100	10	3935	2225	2090	2725	250	805	15	22	0.75	1000	200	14	300	9200	
SCUT 3113	2.3°	3100	13	3950	2240	2100	2735	250	805	15	30	0.75	1000	200	12	400	12000	
SCUT 3116	2.5°	3100	16	4035	2415	2365	2815	250	880	15	37	0.75	1000	200	10	400	15000	
SCUT 3120	2.7°	3100	20	4050	2490	2375	2830	250	880	15	45	0.75	1000	200	8	500	21000	
SCUT 4106	1.5°	4100	6	5120	2195	1770	2665	250	790	19	15	0.75	1000	200	16	300	10200	
SCUT 4110	1.8°	4100	10	4935	2225	2220	2725	250	805	19	22	0.75	1000	200	12	300	12000	
SCUT 4113	2.3°	4100	13	4950	2240	2235	2735	250	805	19	30	0.75	1000	200	10	400	15500	



# V-CUT SERIES

## CNC VARIABLE RAKE ANGLE SHEARS

High and accurate performance of cutting allows you cost-efficiently cut pieces in high volumes.

V-Cut is available in a wide range of models and powers.

Length and shearing thickness can be customized to the highest levels in the category.

Wide range of accessories

Ergonomics

Faster

Economic

User Friendly

### GENERAL SPECIFICATIONS

Durable & powerful framedesign for perfect cutting

Hardened and ground blades

CE standards security and light guards.

Blade clearance and cutting angle automatically adjusted by CNC controller.

Sheet sliders at the back side.

Automatic swing up back gauge for larger sheets

Front support arms T-Slots for easy cutting and feeding material

Ball Transfer table







## FEATURES OF V-CUT SERIES

30

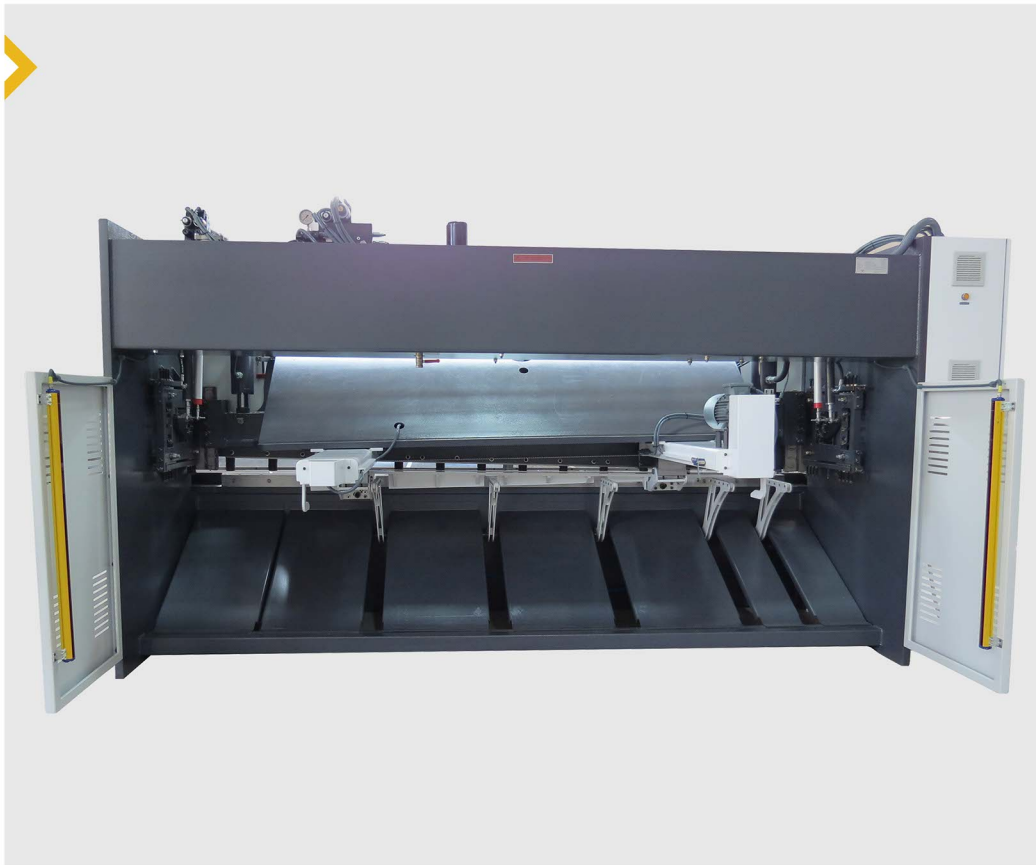

Pneumatic thin sheet support system

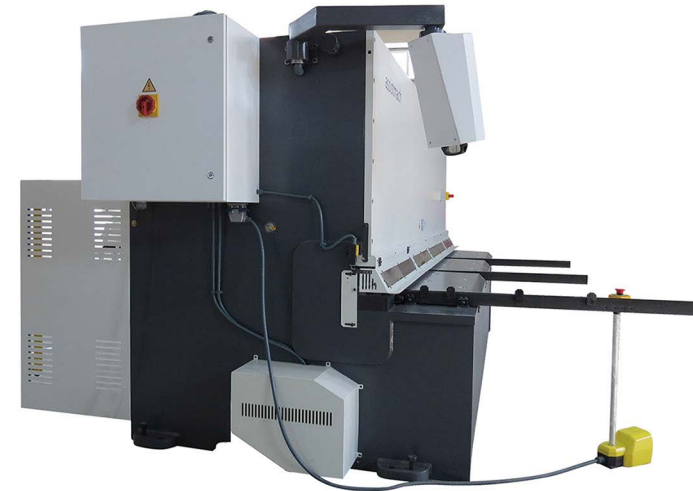

1 meter flip up front fences with flexi-glass  
Iron ball transfer tables  
Hydraulic hold down pistons

## Cybelec CybTouch 8



### CUSTOMER BENEFITS

Very simple to use with intuitive touch screen programming

Higher quality and productivity increase

Powerful features for maximum output

### Easy Operating

- High-contrast touchscreen, with vivid colors
- Simple pages, large keys, clear display with all the information the operator needs
- Intuitive and user-friendly interface
- Complete programming of parts in seconds
- Quick set up of the machine with the EasyCut page.
- Contextual help and warning pop-up

### Better Cutting

- Automatic calculations of the shear functions upon material specifications
- Automatic blade gap
- Automatic cutting angle
- Automatic cutting length
- Automatic back gauge correction
- Automatic back gauge foldaway
- Anti-twist management
- 2/3- position sheet support
- Return to sender function (RTS)
- Front or back gauge management
- Parking position (foldaway function)
- Hold-downs pressure management
- System pressure management
- Sheet position offset, allowing to cut in the middle

### Powerful

- Large cutting sequences and programs can be memorized
- Easy communication via wireless connection to a laptop computer
- Over 10 languages available



## Standard Equipments

- CE-Norm with safety switches and light guards at the back side
- Welded strong steel construction frame
- User friendly CNC Touchscreen control unit
- Automatically adjusted rake angle by CNC
- Adjusted cutting length by CNC
- Iron ball integrated front tables
- Ball screw back gauge.
- 1000mm Flip-up finger guards
- 1500mm Squaring arm with scale T-Slot
- Support arms (L=1000mm)
- Led light for cutting area& Shadow line
- Automatically pressure adjusted solid holddowns
- Sheet slider at the back side
- Top and bottom blades with four sides

## Optional Equipments

- Laser Cutting Line
- Light curtains for finger protection
- Pneumatic sheet support system
- Pneumatic sheet support with return to sender
- Anti twist system
- Back gauge 1250 mm
- Hydraulic swing-up back gauge
- Oil coolant
- Oil heater
- Central lubrication manual or motorized
- Adjustable angle stop 0-180°

32

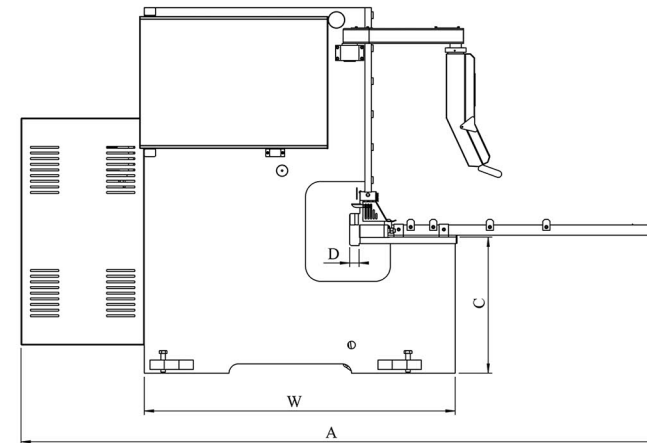
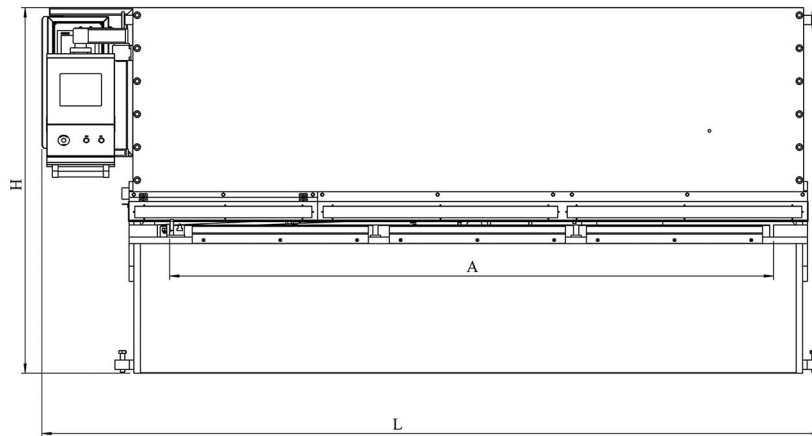





V-CUT SERIES VARIABLE RAKE ANGLE SHEARS

TYPE	Cutting Angle	Cutting Length	Capacity	Length	Width	Height	Width	Throat Depth	Table Height	Hold Down Pistons	Motor	Back Gauge Motor	Back Gauge Range	Back Gauge Speed	Cutting Stroke	Oil Tank	Weight
				Machine Transport Dimension													
VCUT 3106	0.5°..2.5°	3100	6	4100	2360	2165	2650	50	790	15	11	0.75	1000	200	18	200	7500
VCUT 3110	0.5°..2.5°	3100	10	4030	2200	2290	2700	50	805	15	22	0.75	1000	200	14	300	10200
VCUT 3113	0.5°..2.5°	3100	13	4050	2200	2290	2700	50	805	15	30	0.75	1000	200	12	400	12500
VCUT 3116	0.5°..2.5°	3100	16	4190	2375	2515	2900	50	880	15	37	0.75	1000	200	10	400	18000
VCUT 3120	0.5°..2.5°	3100	20	4125	2490	2530	3065	50	880	19	37	0.75	1000	200	9	500	21000
VCUT 4106	0.5°..2.5°	4100	6	5120	2360	2165	2665	50	790	19	11	0.75	1000	200	16	200	10200
VCUT 4110	0.5°..2.5°	4100	10	4935	2225	2290	2700	50	805	19	22	0.75	1000	200	12	300	13000
VCUT 4113	0.5°..2.5°	4100	13	4950	2230	2440	2720	50	805	19	30	0.75	1000	200	10	400	15400
VCUT 4116	0.5°..2.5°	4100	16	5195	2415	2595	2900	50	880	19	37	0.75	1000	200	8	400	22000
VCUT 4120	0.5°..2.5°	4100	20	5080	2490	2800	3065	50	880	21	37	0.75	1000	200	6	500	29000
VCUT 6106	0.5°..2.5°	6100	6	7120	2360	2700	2665	50	790	32	22	0.75	1000	200	10	300	22000
VCUT 6110	0.5°..2.5°	6100	10	6950	2225	2750	2700	50	805	32	30	0.75	1000	200	8	300	25000
VCUT 6113	0.5°..2.5°	6100	13	7175	2450	2900	2700	50	965	32	37	0.75	1000	200	6	400	32500
VCUT 6116	0.5°..2.5°	6100	16	7080	2415	2950	2900	50	1000	32	45	0.75	1000	200	6	500	36000
VCUT 6120	0.5°..2.5°	6100	20	7125	2490	3200	3065	50	1050	32	45	0.75	1000	200	5	500	55000





# M-CUT SERIES

## DIRECT-GEAR MOTORIZED GUILLOTINES

### GENERAL SPECIFICATIONS

Welded steel construction  
High carbon/high chrome, two edged top, four edged bottom cutting blades.  
Cutting beam working in perfectly sliding, durable teflon slideways  
Easy maintenance clutch system  
Easy blade gap adjustment  
Mechanical sheet clamping system

Direct  
Drive  
Technology

User  
Friendly  
Control

High  
Speed  
Cutting

Low  
Power  
Consumption

Maintenance  
Free

CE







36

### Standard Equipments

- Manual backgauge with 750 mm stroke
- Squaring arm with ruler
- Foot pedal
- Front sheet holding arms
- Finger protection cages
- Rear protection cages with photocell
- Cutting unit counter
- Cutting line illumination

### Optional Equipments

- NC control backgauge with 750 mm stroke
- NC control backgauge with 1000 mm stroke
- Pneumatic thin sheet support system
- Rear protection cages with light barrier
- 0-180 ° angular cutting device
- Cutting line shadow illumination
- Elgo control unit
- Squaring arm and front sheet holding arms other than standart length
- Front operated manuel back gauge with ball screw

MCUT

TYPE	Cutting Length	Capacity	Length	Width	Height	Table Width	Table Height	Motor	Back Gauge Range	Cutting Stroke	Weight
	A	St 42	L	W1	H	W	C				
	mm	mm	mm	mm	mm	mm	mm	kW	mm	1/min	kg
Machine Transport Dimension											
MCUT 1303	1360	3	1920	1750	1260	390	810	3	750	35	1250
MCUT 2003	2060	3	2650	1750	1260	390	810	4	750	35	1750
MCUT 2525	2560	2.5	3150	1750	1260	390	810	4	750	35	1950



37

### Standard Equipments

- NC control backgauge with 750 mm stroke
- Squaring arm with t slot, stoper and ruler
- Foot pedal • Cutting unit counter
- Front sheet holding arms
- Finger protection cages
- Rear protection cages with photocell
- Table with ball transfer
- Cutting line illumination

### Optional Equipments

- NC control backgauge with 1000 mm stroke
- Pneumatic thin sheet support system
- Rear protection cages with light barrier
- 0-180° angular cutting device
- Cutting line shadow illumination
- Elgo control unit
- Squaring arm and front sheet holding arms other than standart length
- Front operated manual back gauge with ball screw

MCUT

TYPE	Cutting Length A	Capacity St 42	Length L	Width W1	Height H	Table Width W	Table Height C	Motor kW	Back Gauge Range mm	Cutting Stroke 1/min	Weight kg
MCUT 2004	2060	4	2800	2250	1400	445	800	7.5	750	41	1250
MCUT 2504	2560	4	3225	2250	1400	445	800	7.5	750	41	1750
MCUT 3004	3060	4	3770	2250	1400	445	800	7.5	750	41	1950



38

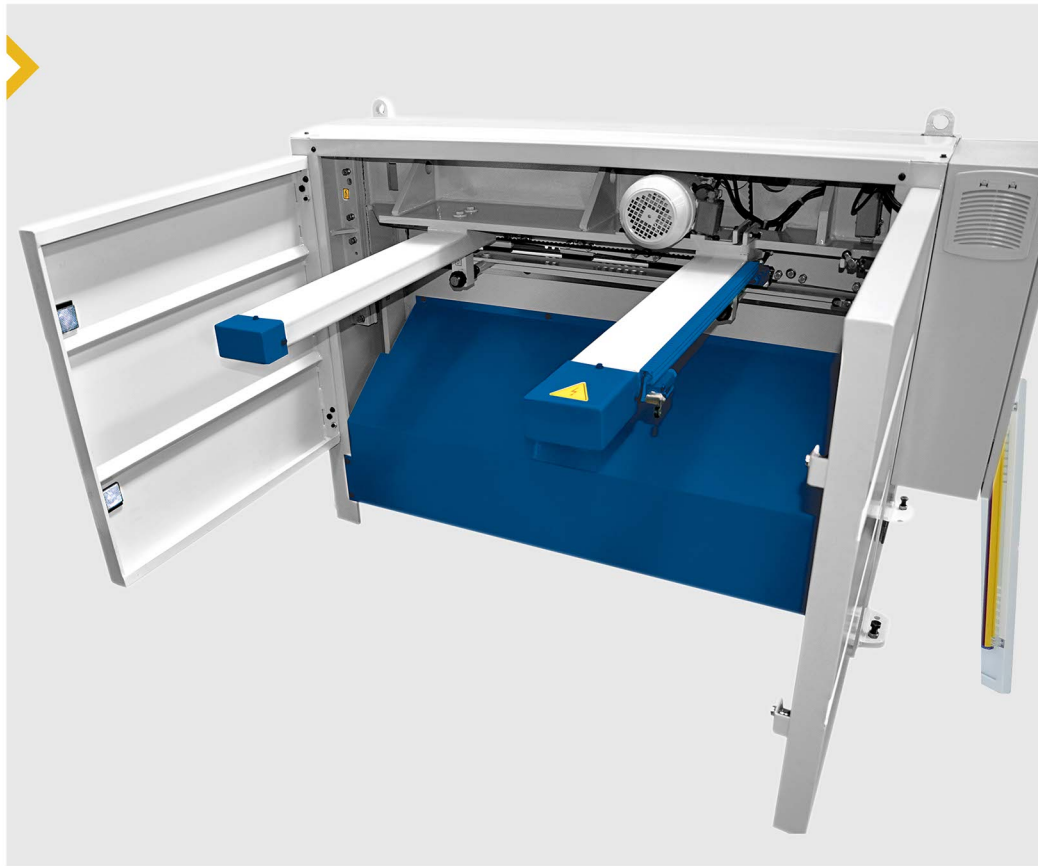



39

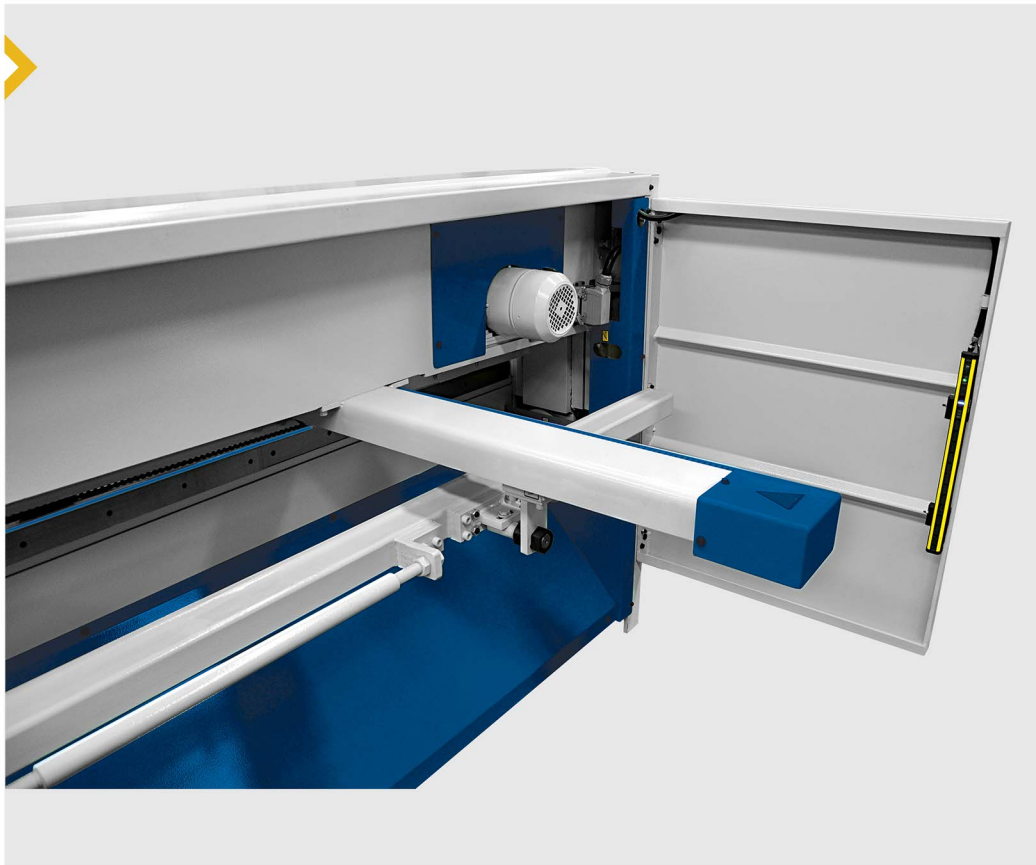



Assistmach San. ve Tic A.Ş.

Kayapa Mh. Kayapa OSB, Nergiz Cd. No: 11  
16315 Bursa Turkey

info@assistmach.com

P. +90 224 453 50 20

 Assistmach

 Assistmach

[www.assistmach.com](http://www.assistmach.com)

